

DESCRIPTION	
CODE	FINISH
SCUP 200x75	PLASTIC

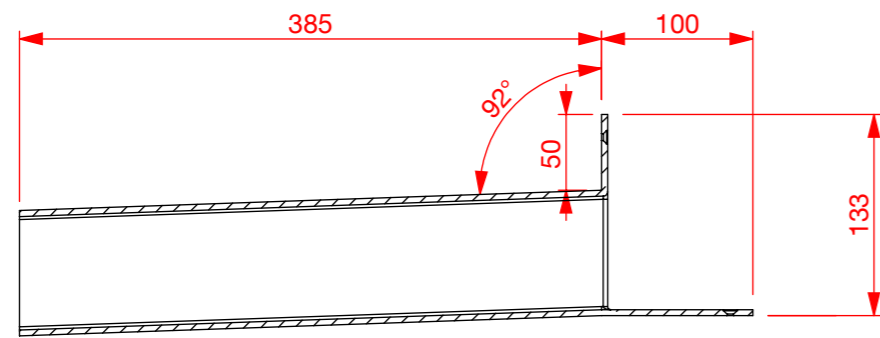

SECTION G-G

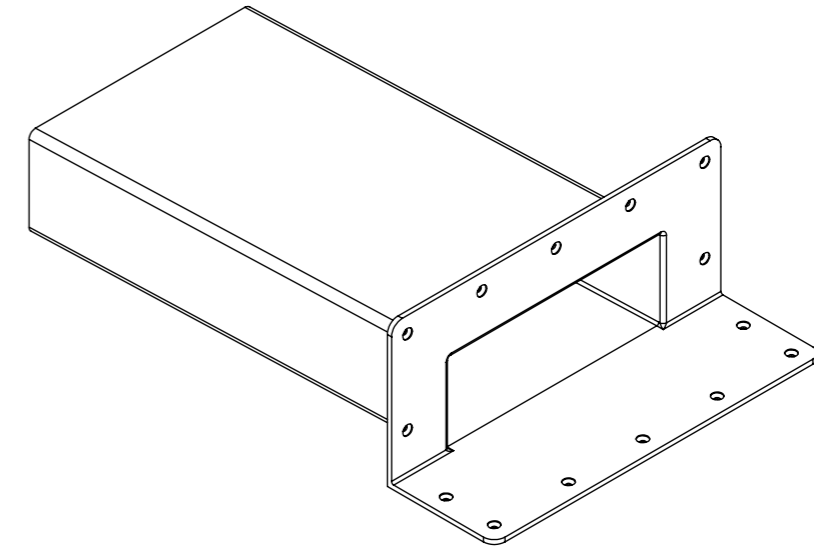
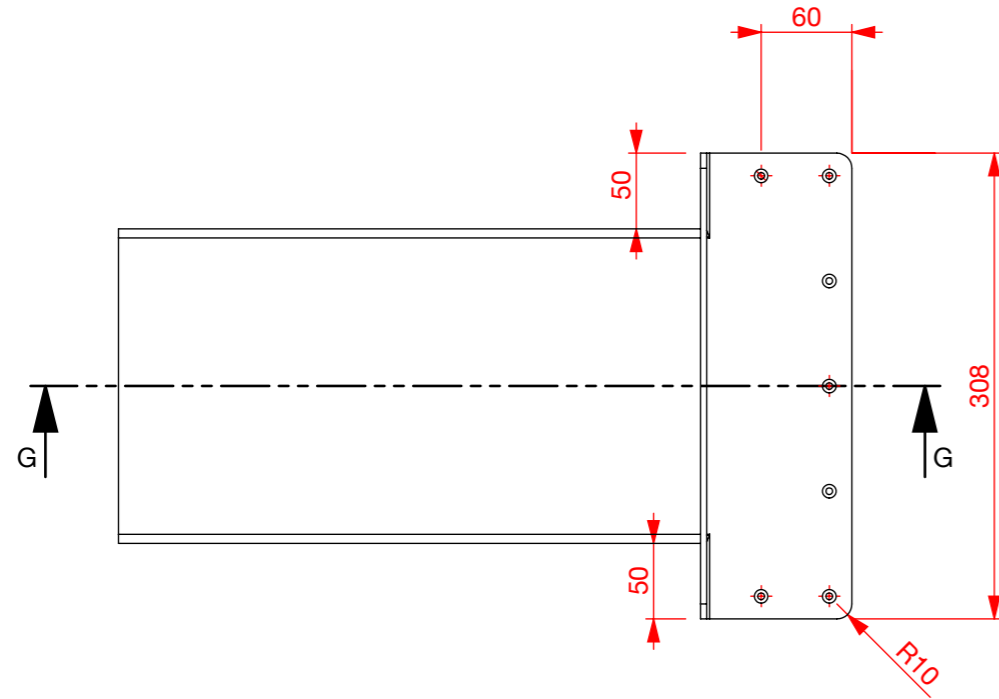
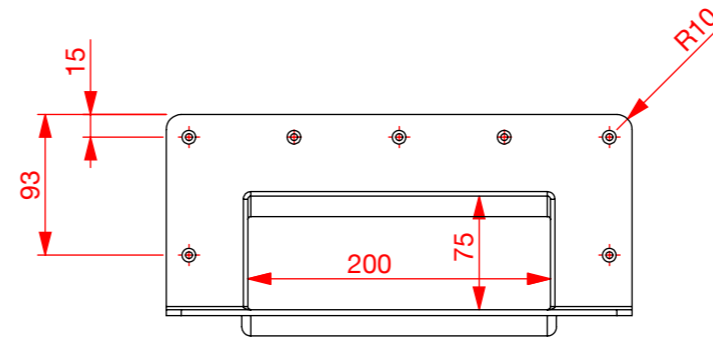

XXX	XXX	XXX	SL	XXX
REVISION	CHANGE	DESCRIPTION	DRAWN	DATE
DO NOT SCALE DRAWING		TITLE		
REQUESTED	DATE	SCUPPER 200X75X90 DEGREE 385 LONG		
XXX	XXX			
DRAWN	DATE	APPLICABLE STANDARD(S):		
S.L.	28.2.2019			
APPROVED	DATE	DRAWING REF NUMBER		
		SCUP200X75		
MATERIAL		HDPE		
TOOL NUMBER		0.0		
PART WEIGHT(GRAMS)		0.0		
FILE		S/CAD FILES/2019/DRAINAGE/INJ/PLASTIC SCUPPER NON CLAMPING/PLASTIC SCUPPER 200X75		SHEET 1 OF 2
A3	UNITS = MM	SCALE (UOS) 1 : 5		

DISCLAIMER : THE DESIGN SUGGESTION IS PROVIDED FOR EVALUATION PURPOSES ONLY.
IT IS NOT TO BE CONSIDERED A FULL DESIGN AS WE ARE NOT THE CONSULTING ENGINEERS. WE ARE MANUFACTURERS. WE ARE NOT PRIVY TO ALL THE INFORMATION PERTAINING TO THIS MATTER AND WE HAVE NO CONTROL OVER THE PROJECT INSTALLATION OF THE PRODUCT. THE DESIGN SUGGESTION IS PROVIDED WITHOUT OBLIGATION. DESIGN IS TO BE CONFIRMED AND APPROVED BY THE ARCHITECT, HYDRAULICS ENGINEER, OR PROJECT MANAGER. ACCURATE MEASUREMENTS SHOULD BE CONFIRMED BY THE PERSON APPROVING THE DESIGN. ALLPROOF ACCEPTS NO LIABILITY FOR THE IMPROPER USE OF THE DESIGN SUGGESTION.