

DESCRIPTION	
CODE	FINISH
SUREFLOW100 OFLOW	BLACK PLASTIC

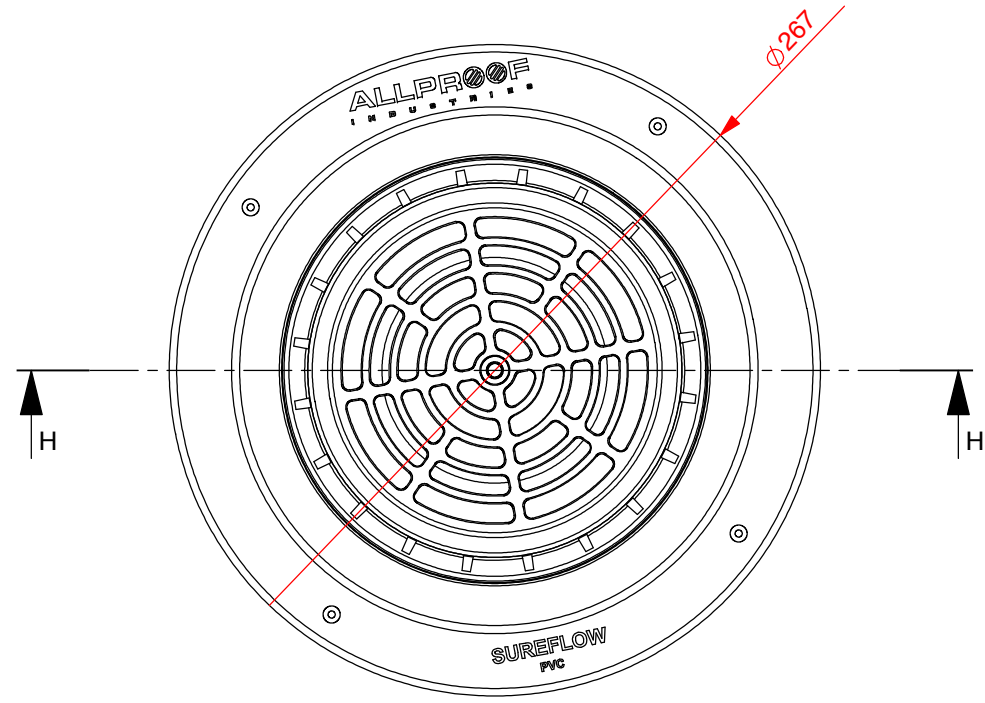

TOP

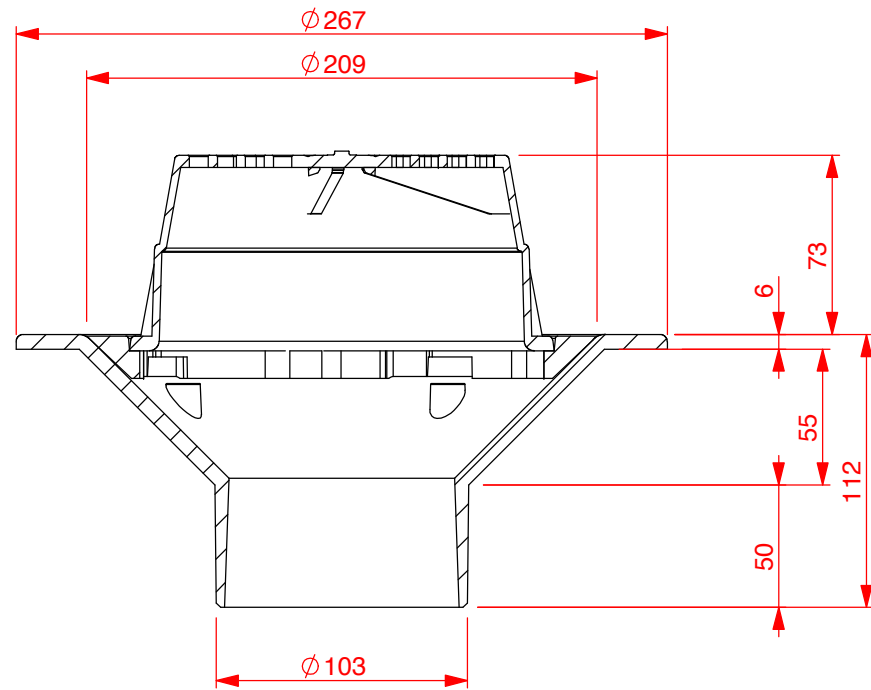

SECTION H-H

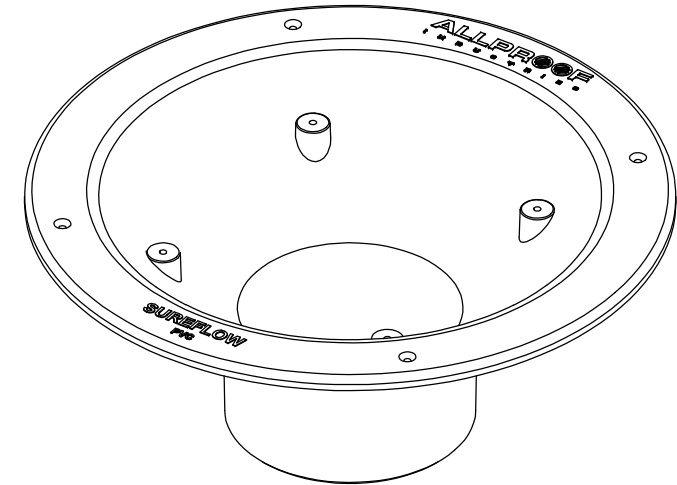
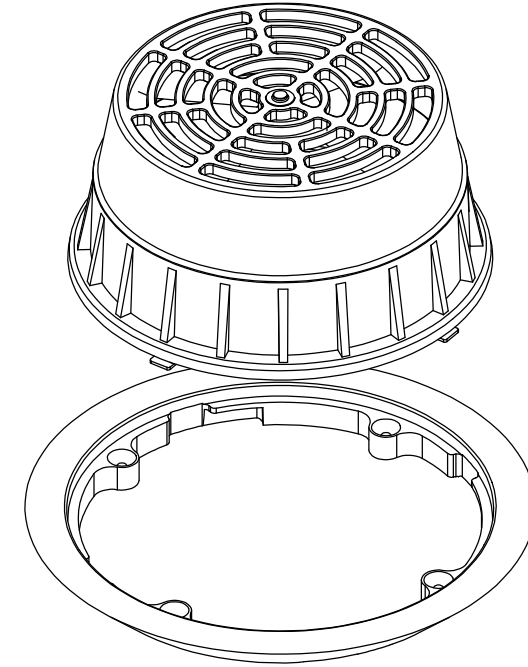

REVISION	CHANGE	DESCRIPTION	DRAWN	DATE
DO NOT SCALE DRAWING		TITLE		
REQUESTED	AJ	DATE	2.6.2015	
DRAWN	S.L.	DATE	2.6.2015	
APPROVED		DATE		
MATERIAL		APPLICABLE STANDARD(S):		
ABS, PVC		DRAWING REF NUMBER	SUREFLOW100 OFLOW	
FILE	S/CAD FILES/2014/DRAINAGE/NJ/SF RISER 100_PLANTER BOX	SCALE	1 : 2 (UOS)	
A3	UNITS = MM			SHEET 5 OF 18

DISCLAIMER - THE DESIGN SUGGESTION IS PROVIDED FOR EVALUATION PURPOSES ONLY.
IT IS NOT TO BE CONSIDERED A FULL DESIGN AS WE ARE NOT THE CONSULTING ENGINEERS, WE ARE MANUFACTURERS. WE ARE NOT PRIVY TO ALL THE INFORMATION PERTAINING TO THIS MATTER AND WE HAVE NO CONTROL OVER THE PROJECT INSTALLATION OF THE PRODUCT. THE DESIGN SUGGESTION IS PROVIDED WITHOUT OBLIGATION. DESIGN IS TO BE CONFIRMED AND APPROVED BY THE ARCHITECT, HYDRAULICS ENGINEER, OR PROJECT MANAGER. ACCURATE MEASUREMENTS SHOULD BE CONFIRMED BY THE PERSON APPROVING THE DESIGN. ALLPROOF ACCEPTS NO LIABILITY FOR THE IMPROPER USE OF THE DESIGN SUGGESTION.